

 **Bornemann**

Chemical Industry

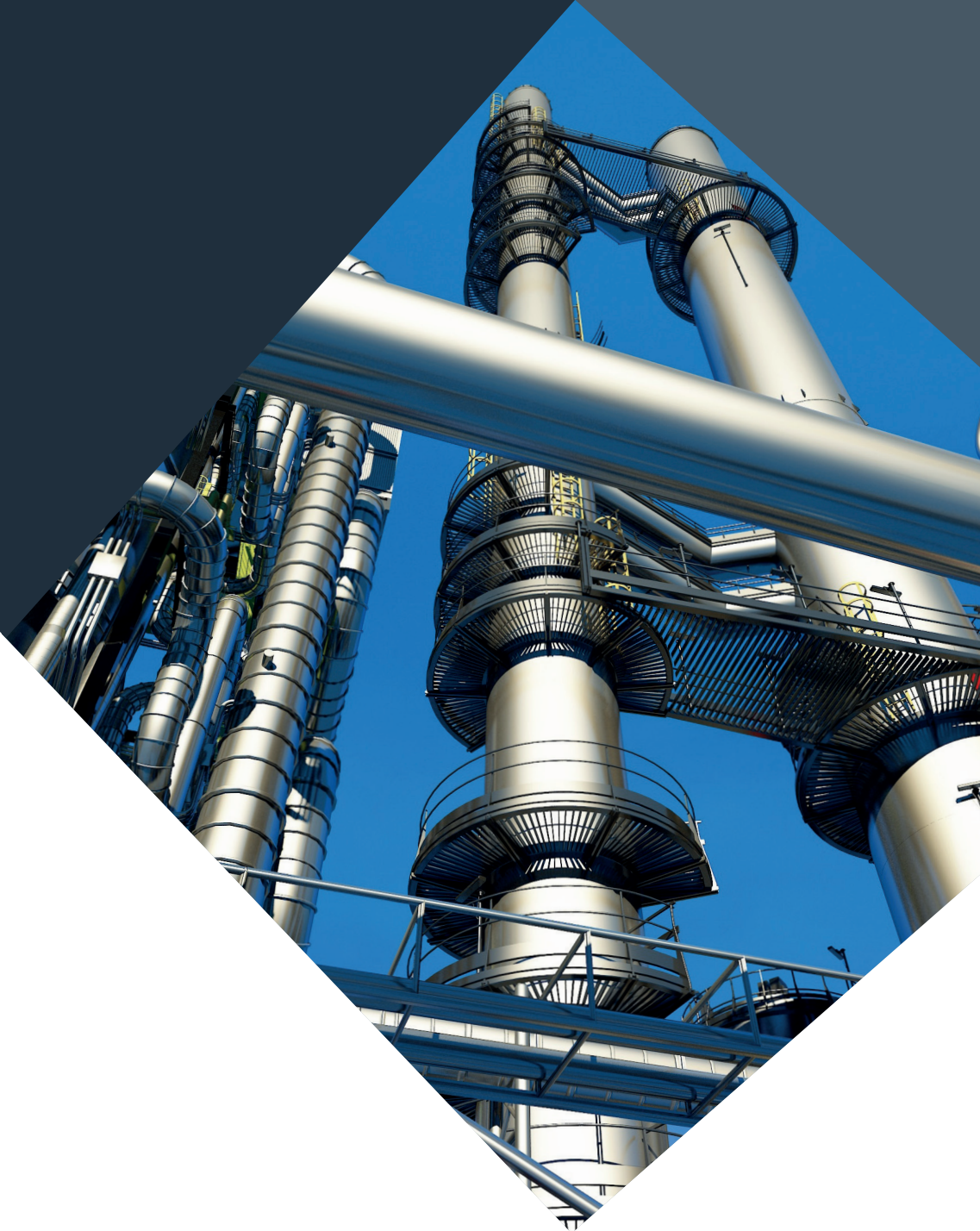

ITT

ENGINEERED FOR LIFE

Bornemann - Expertize in Chemical Applications

Tools of Choice

Plastics and chemicals have become a major part of our surrounding. Chemicals abound in almost all walks of life. There's hardly an end product today that does not incorporate chemical additives. Production of base chemicals, petrochemicals, polymers and fine and specialty chemicals entails complex processes. Hazardous substances, high pressures, and the risk of explosion are part and parcel of everyday work in the chemical industry and result in the highest safety requirements for people, plants, machines, and the environment.

Processes are constantly being optimized in regard to productivity and energy efficiency. In this field where Bornemann is your expert partner. Bornemann pumps meet the most stringent requirements even in complex processes and are always a profitable solution. They reliably deliver both low- and high-viscosity media, also with non-Newtonian viscosity and aggressive and abrasive media.



In the chemical industry, Bornemann pumps are employed in highly specialized fields of application. The properties of the media to be delivered often change over the course of the production process. It is in this field that Bornemann Twin Screw Pumps are renowned for their flexibility and up-time. Thanks to their speed control, they can be optimally adjusted to the respective

consistency of the medium. New technologies and processes, shifting demands, and intense competition – increasing your knowledge is a constant necessity. Bornemann is your expert partner when it comes to exploring even the most unconventional solutions – the insider's choice among specialists!

Bornemann - Twin Screw Pumps

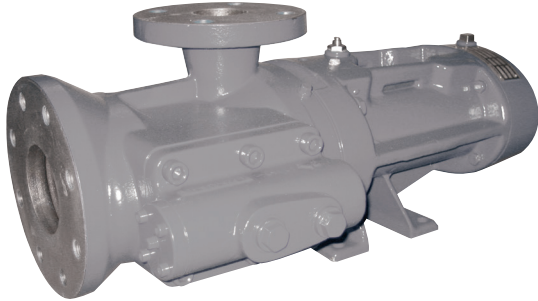

SLI Compact Pump

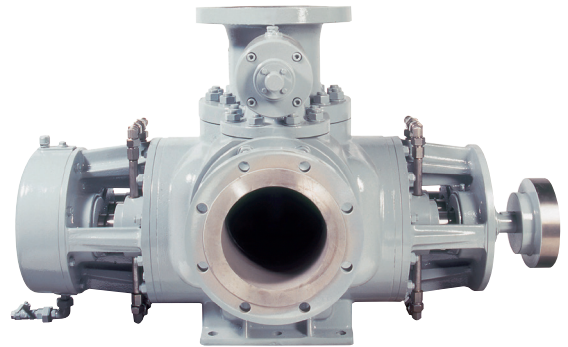

W/V Universal Pump



SLW Series



SLH-4 Series Hygienic Pump

| | Capacity | | Differential Pressure | | Viscosity | | Max. Product Temperature | |
|-----------------------------------|-------------------|-------------|-----------------------|--------------|--------------------|-----|--------------------------|----------|
| | m ³ /h | gpm | bar | psi | mm ² /s | cSt | °C | °F |
| SLI Compact Pump | max. 180 | max. 790 | max. 16 | max. 230 | max. 100,000 | | max. 120 | max. 250 |
| SLW Series | max. 800 | max. 3,520 | max. 16 | max. 230 | max. 10,000 | | max. 300 | max. 570 |
| W/V Universal Pump | 10 - 2,800 | 50 - 12,300 | max. 40/60 | max. 600/900 | 0,5 - 200,000 | | max. 350 | max. 660 |
| SLH-4 Series Hygienic Pump | max. 300 | max. 1,300 | max. 25 | max. 360 | max. 1,000,000 | | max. 180 | max. 350 |

Markets & Selected Applications

Markets

- Transfer, Dosing, Processing and Unloading
- Paint Industry
- Construction Chemistry
- Finished Products (e.g. paints, water-soluble varnishes and varnishes containing solvents, isocyanates, glues)
- Raw Materials (e.g. resins, polyols, binders, solvents)
- Petrochemicals
- Energy and Fuel Oil
- Tank Storage
- Maritime Logistics

Polymers / Fine Chemicals



Country: United States
Pump Type: W10.6zk
Product: 1-octene with 4,5% melted polymers - flash recirculation
Capacity: 450 m³/h
Pressure: 40 bar
Viscosity: 2 - 1,000 cSt

Petrochemicals, Natural Gas, Biofuels



Country: The Netherlands
Pump Type: SLI 80
Product: Gasoil / Naphtha
Capacity: 17 m³/h
Pressure: 4 bar
Viscosity: 1 - 10 cSt

Paint Industry



Country: Austria
Pump Type: SLH
Product: Binder, Paint
Capacity: 13-35 m³/h
Pressure: 6-9 bar
Viscosity: 4,000 - 22,000 cSt

Cosmetic Raw Materials



Country: Germany
Pump Type: SLH-4G 3000
Product: Raw Chemicals
Capacity: 18 m³/h
Pressure: 4 bar
Viscosity: 10,000 cSt

Bornemann - Operating Principles

Non-Product Lubricated Synchronisation (SLI / SLH / W / V)

Twin Screw Pumps are rotating positive displacement pumps, using two screws to convey the product along the screw axis. The contact-free intermeshing screws and the housing form closed chambers, constantly moving product from suction to discharge. Due to the arrangement of the pump elements, the delivery direction is reversible simply by reversing the shaft rotation. Axial delivery results in smooth, low-pulsation pumping. Products sensitive to shear are subjected to hardly any stresses during delivery, thus ensuring that the media retain their volumes, look, and properties.



Product Lubricated Synchronisation (SLW)

Twin Screw Pumps conveying elements of SLW Series consist of two screws, forming a hermetically sealed chamber with the pump casing. Special characteristic of the pump is that the screws not only convey the product, but also transmit the torque.

By the rotation of the screws, the product is conveyed from the suction side to the discharge side, along the screw axis. Standard arrangement shows the suction side on axial positioning, and topside discharge outlet.

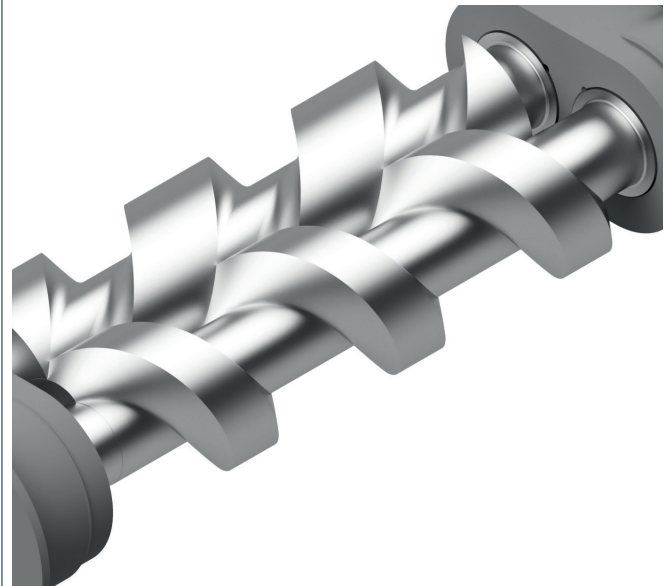

User Advantages - Made by Bornemann

- ATEX inside compliant designs available
- Non-contact pump elements
- Dry operation possible

- Bornemann Twin Screw Pumps are equally suited to delivering high- and low-viscosity products
- Low-pulsation and low product stresses
- Adaptation to changing process parameters thanks to speed control

User Advantages - Made by Bornemann

- Fast & Easy Maintenance (gearless, one mech. seal only)
- Hermetic (MAG-Drive) Design available

- ATEX outside and TA Luft compliant designs available
- Self-priming, outstanding aspiration power
- High delivery rate and pressure range
- Less wear parts

Safety Regulations - ATEX, TA Luft, EHEDG

Requirements of ATEX Directive

According to the European Directive 2014/34/EU, manufacturers are obliged to design their products suitable for the safe use in the explosive atmosphere when placing a product on the European Single Market.

The Directive for example covers the classification of a product and appoints essential health and safety requirements for the design and construction of products for potentially explosive atmosphere.

The Industrial Safety Regulation encourages Operators to operate equipment of specific categories to ensure safe operation.

Technical Execution

Twin Screw Pumps are used in various Industrial Sectors where flammable liquids are pumped.

Flammable liquid-/gas-/air-mixtures can arise.

Fields of Application

Especially during the nearly complete emptying process in tanks, tank storages, vessels or tank wagons, temporary conveyance of hydrocarbon-air-mixtures appears.

Bornemann pumps, specifically designed for these processes, can perform the complete emptying process safely, cost-effective and without complex processing technology (e.g. flow sensor, nitrogen pendulum system).

Bornemann pumps meet highest standards, operate in complex processes and ensure economic and efficient solutions.

TA Luft

The Technical Guideline for Air Pollution Control (TA Luft) has been approved according to the German Federal Law on the Prevention of Immissions (BImSchG).

TA-Luft applies in cases of conveyance of harmful media in classified installations as this guideline limits the handling of fluids to technically sealed installations.

Pumps are a central component, such as magnetic drive pumps, pumps with double mechanical seal and sealing medium. The Bornemann product portfolio includes pump executions that meet these requirements. Retrofitting solutions available on request.

EHEDG

EHEDG certification guarantees a cleaning of the pump without dismantling it. Bornemann SLH Pumps are EHEDG-certified.

For certification, the pump has to pass a test in an EHEDG institute, where the process is simulated. After contamination of the pump, the cleaning process starts. The results will be compared with a "proven-as-cleaned" reference. Final approval is given when all areas are cleaned.

Furthermore, the Twin Screw Pump can even do the cleaning process due to the fact that the pump speed range of 1:15 plus proportional flow characteristics ensure process cycles and cleaning procedures with just one pump.



ATEX Zone I - Inside a Twin Screw Pump

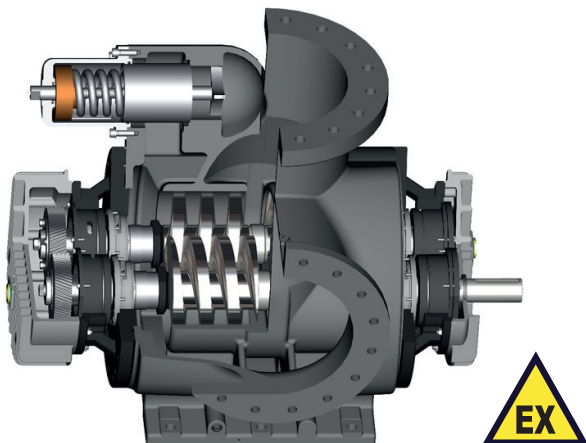

Bornemann offers pump types that are approved for conveyance of flammable mixtures. Model-specific advantages of the Twin Screw Pump can be fully utilized. The pumps are suitable for conveyance of intermittent explosive mixtures and can be operated in areas where explosive atmospheres may occur.



i-ALERT Monitoring Solution

Sensor | App | Ai Platform



What it Does:

Monitor

Tracks vibration, temperature & run-time hours 24/7/365.

Alarm

Takes high resolution data when an alarm condition occurs and stores it for later analysis.

Trend

Captures data every 1-60 minutes and has up to 170 days of on-board storage.

Analyze

Diagnose machine faults with vibration tools. Fast Fourier Transform (FFT) & Time Wave Form Analysis.

Environment

Rated for any industrial environment. Water & dust resistant. Intrinsically Safe with a 3-year battery life (use dependent).

Wireless

Sync data via Bluetooth Smart enabled smartphones and tablets.

Online Marketing

Monitor and manage all of your i-ALERT enabled machines in one place - i-ALERT Ai Online Platform. This subscription service requires no software to download or dedicated hardware to run.

www.i-alert.com

ATEX Zone 0 AEx ia IIB Ga (Groups C & D)

How it Works:

1. Activate

The i-ALERT devices are light activated by removing the sticker. The i-ALERT® device begins wirelessly broadcasting once activated.



2. Auto Configuration

The i-ALERT device averages the vibration over 25 hours of run-time and sets the alarm levels to 2x average (0.1-1.5ips minimum). Temperature alarm default to 80°C (176°F).

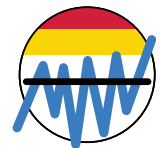

OR

2. Manual Configuration

User manually sets the alarm thresholds via the i-ALERT® mobile application.



3. Monitor

The i-ALERT sensor is configurable to check every 1-5 minutes. If two consecutive readings are above alarm threshold the i-ALERT device will go into alarm.



Spend less time collecting data and more time fixing problems. The i-ALERT mobile app has the ability to scan multiple i-ALERT devices within range to quickly and safely inspect multiple machines.



Dashboard

Simple, intuitive dashboard to track vibration, temperature, run-time & battery life.



Trending

Trend vibration, temperature, & kurtosis to monitor any changes in the equipment operation.



BOM

Load the as built of materials based on the pump serial number.

ITT Bornemann - Worldwide

Europe, Middle East, Africa

ITT Bornemann GmbH
Industriestrasse 2
31683 Obernkirchen
GERMANY
Tel: +49 5724 390-0
Fax: +49 5724 390-290
info.bornemann@itt.com
www.bornemann.com



Germany – Headquarters

North America

ITT Goulds Pumps Inc.
12510 Sugar Ridge Blvd
Stafford 77477, TX
UNITED STATES OF AMERICA
Tel: +1 281 504 6300
Fax: +1 281 504 6399
info.bornemann@itt.com
www.bornemann.com

Latin America

ITT Argentina - Bombas Bornemann
Mariano Moreno 4380
Munro
B 1605BOF
Prov. Buenos Aires
ARGENTINA
Tel: +54 11 4756 8008
Fax: +54 11 4756 5541
info.bornemann@itt.com
www.bornemann.com

Asia Pacific

ITT Fluid Technology Asia Pte. Ltd.
1 Jalan Kilang Timor #04-06
Singapore 159303
SINGAPORE
Tel: +65 6276 3693
Fax: +65 6276 3685
ipgsin@itt.com
www.bornemann.com

China

ITT Fluid Technology Co. Ltd.
Room 902, Tower A
No. 100 Zunyi Road
Changning District
Shanghai 200051
CHINA
Tel: +86 21 2231 2388
Fax: +86 21 2231 2308
info.bornemann@itt.com
www.bornemann.com

Australia

ITT Industrial Process
29 Paramount Drive
WANGARA, WA 6065
AUSTRALIA
Tel: +61 8 9302 1855
Fax: +61 8 9302 1856
info.bornemann@itt.com
www.bornemann.com

Russia

ITT IP - ITT Industries Rus LLC
125167 Leningradsky prospekt, 37A
building 14, 3rd floor
Moscow
RUSSIA
Tel: +7 495 223 0650
Fax: +7 495 223 0651
info.rus@itt.com
www.bornemann.com



ENGINEERED FOR LIFE

